

6th ELEMENT /W

EN INSTALLATION INSTRUCTIONS
FR INSTRUCTIONS D'INSTALLATION
DE INSTALLATIONSANLEITUNG
PT INSTRUÇÕES DE MONTAGEM
ES INSTRUCCIONES DE MONTAJE

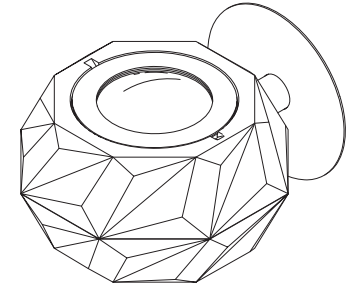

6th ELEMENT /W



EN Warning: The light source contained in the luminaire should be replaced only by the manufacturer. Do not use this equipment in areas containing chemical agents: acids, solvents, paints, silicones, coatings, etc.

FR Advertissement: La source de lumière contenue dans la luminaire doit être remplacée par le fabricant. En cas d'anomalie détectée, contactez le fabricant. Ne pas utiliser l'équipement dans les zones qui contiennent des agents chimiques: acides, solvants, peintures, silicones, vernis, etc.

DE Warnung: Die in der Leuchte enthalten Lichtquelle sollte nur vom Hersteller ersetzt werden. Verwenden Sie dieses Gerät nicht in Bereichen mit chemischen Mitteln: Säuren, Lösungsmittel, Farben, Silikone, Beschichtungen etc.

PT Atencão: A fonte de luz contida na luminária deve ser substituída unicamente pelo fabricante. Qualquer anomalia detectada contactar o fabricante. Não utilizar o equipamento em zonas que contenham agentes químicos: ácidos, solventes, tintas, silicones, vernizes, etc.

ES Atención: La fuente de luz contenida en la luminaria debe ser sustituida unicamente por el fabricante. Cualquier anomalia detectada contactar con el fabricante. No utilizar la luminaria en zonas que contengan agentes químicos: ácidos, disolventes, pinturas, siliconas, barnices, etc."



EN Caution, risk of electric shock.

FR Attention, risque de choc électrique.

DE Achtung, Gefahr eines Stromschlags.

PT Cuidado, risco de choque elétrico.

ES Precaución, riesgo de descarga eléctrica.



EN If glass or diffuser break or crack, please replace it.

FR En cas de casse ou fissurement, remplacez le verre ou diffuseur.

DE Bei Bruch oder Riss, Glas oder Diffuser ersetzen.

PT Em caso de quebra ou fissura, substituir o vidro ou difusor.



ES En caso de rotura o fisura, sustituir el vidrio o difusor.



EN Read carefully the general terms and conditions of use and environmental concern with recycling attached. | **FR** Lire attentivement les conditions générales d'utilisations et de préoccupation environnementales avec les recyclage ci-joint. | **DE** Bitte lesen Sie de Allgemeinen Geschäftsbedingungen und Umweltbewusstsein über Recycling angeschlossen. | **PT** Ler atentamente as condições gerais de uso e preocupação ambiental com a reciclagem, em anexo. | **ES** Lea atentamente las condiciones generales de uso y preocupación ambiental con el reciclaje adjuntos.

EN We reserve the right to make changes on technical specifications, design and installation leaflet without prior notice. | **FR** Sous réserve de modifications au niveau de la conception, des spécifications techniques et de la notice. | **DE** Änderungen von Entwurf, technischen Daten und Bedienungsanleitungen bleiben vorbehalten. | **PT** O fabricante reserva-se no direito de realizar modificações no desenho, especificações técnicas e folheto, sem aviso prévio. | **ES** El fabricante se reserva el derecho de realizar modificaciones en el diseño, las especificaciones técnicas y el folleto.

6th ELEMENT /W

W	mA	V	 (mm)	 (mm)	 Ø	 (mm)
1x8	220	34	140x160x80	200x200	Ø145	10-25
2x8	440	34	140x160x80	200x200	Ø145	10-25

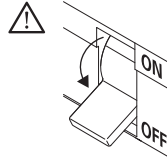

LENS AND DIFFUSER OPTIONS
 OPTION LENTE ET DIFFUSEUR
 OPTION LINSEN UND DIFFUSER
 OPCÃO LENTES E DIFUSORES
 OPCIÓN LENTES Y DIFUSORES

50° LENS OPTION
 OPTION LENTE 50°
 OPTION 50° LINSE
 OPCÃO LENTE 50°
 OPCIÓN LENTE 50°

80° LENS OPTION
 OPTION LENTE 80°
 OPTION 80° LINSE
 OPCÃO LENTE 80°
 OPCIÓN LENTE 80°

DIFFUSER OPTION
 OPTION DIFFUSEUR
 OPTION DIFFUSER
 OPCÃO DIFUSOR
 OPCIÓN DIFUSOR

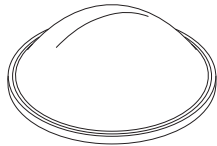

(x2)



(x2)

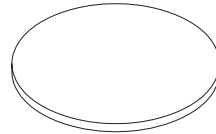

(x2)

15 - 6th ELEMENT /W

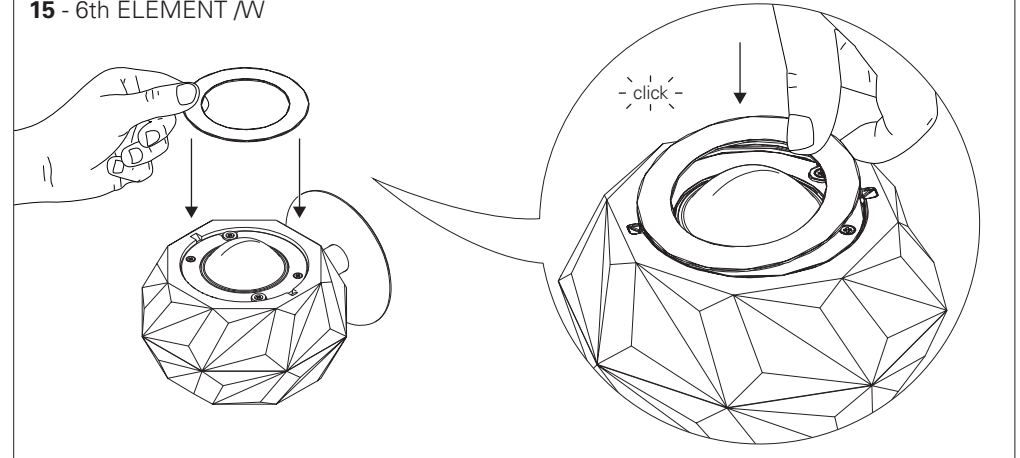

1 - 6th ELEMENT /W

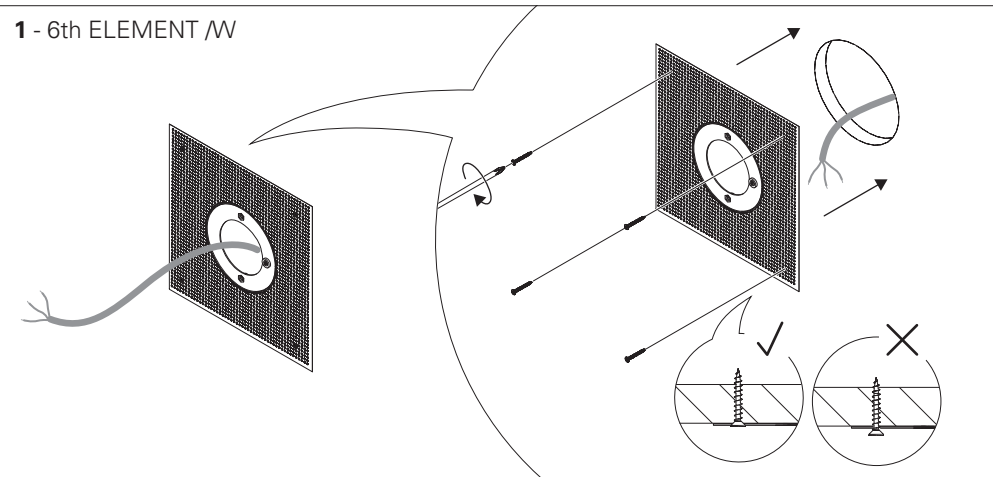

12 - 6th ELEMENT /W

LENS AND DIFFUSER
OPTION LENTE ET DIFFUSEUR
OPTION LINSE UND DIFFUSER
OPÇÃO LENTE E DIFUSOR
OPCIÓN LENTE Y DIFUSOR

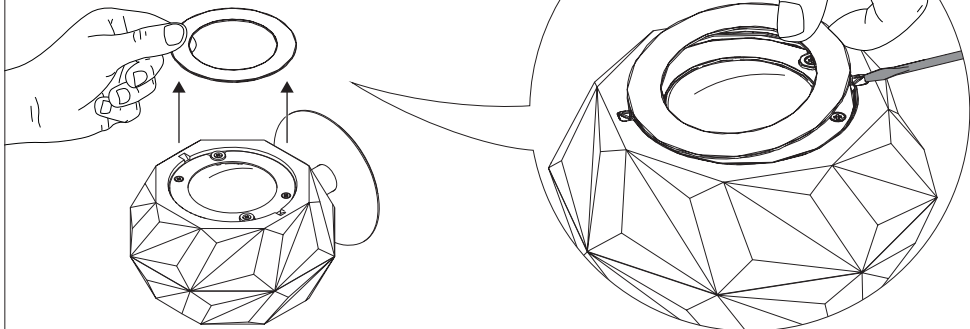

2 - 6th ELEMENT /W

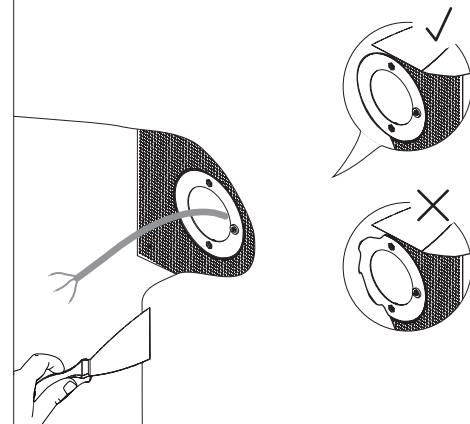

3 - 6th ELEMENT /W

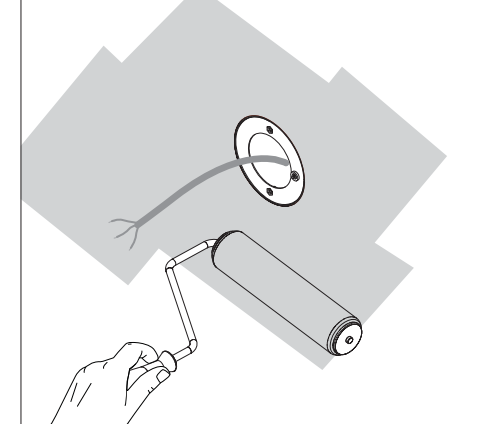

13 - 6th ELEMENT /W

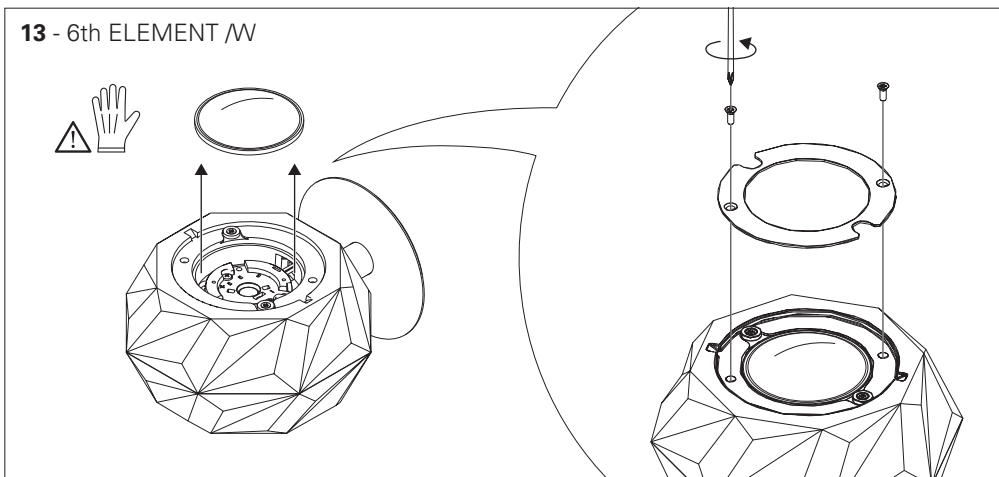

4 - 6th ELEMENT /W

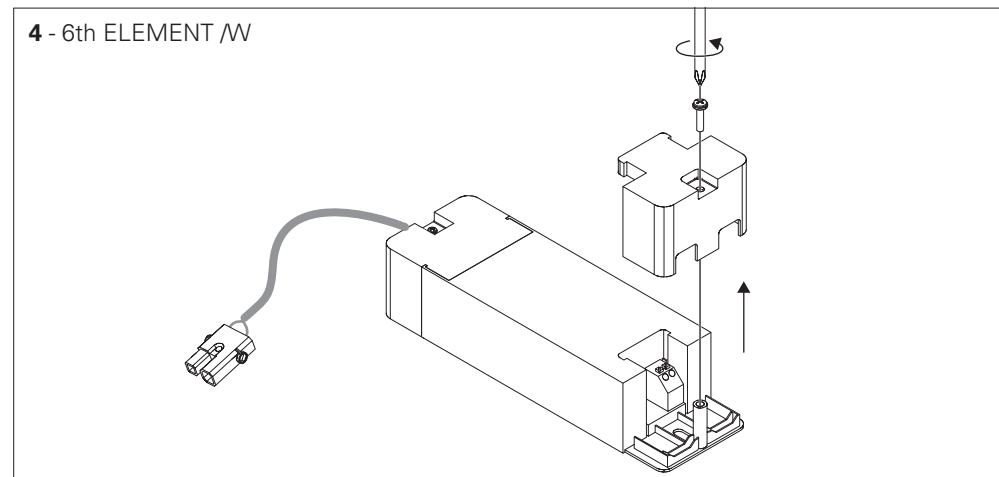

14 - 6th ELEMENT /W

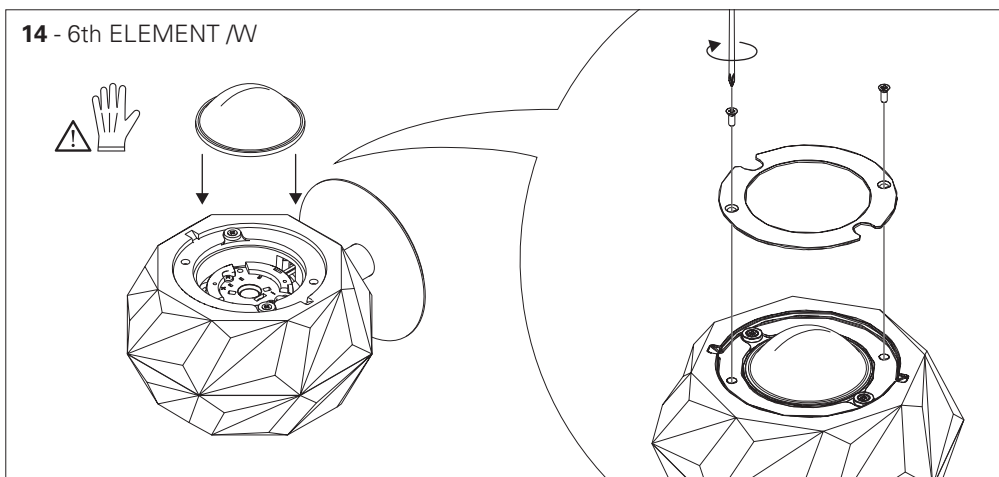

5 - 6th ELEMENT /W

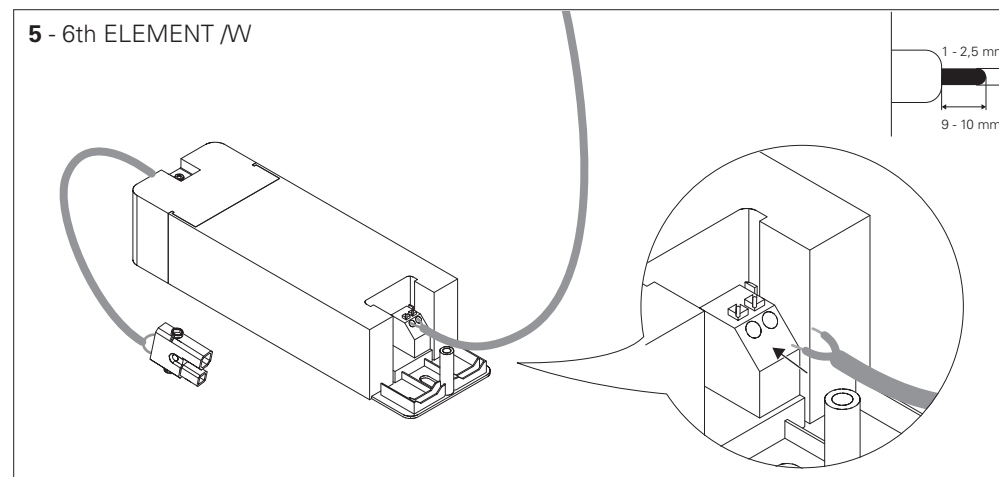

6 - 6th ELEMENT /W HF

STANDARD POWER SUPPLY
CÁBLAGE STRANDARD
STANDARD VERDRAHTUNG
ALIMENTAÇÃO ELÉCTRICA STANDARD
ELECTRIFICACIÓN ESTÁNDAR

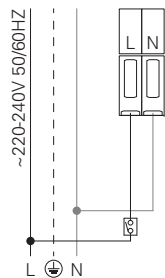

7 - 6th ELEMENT /W

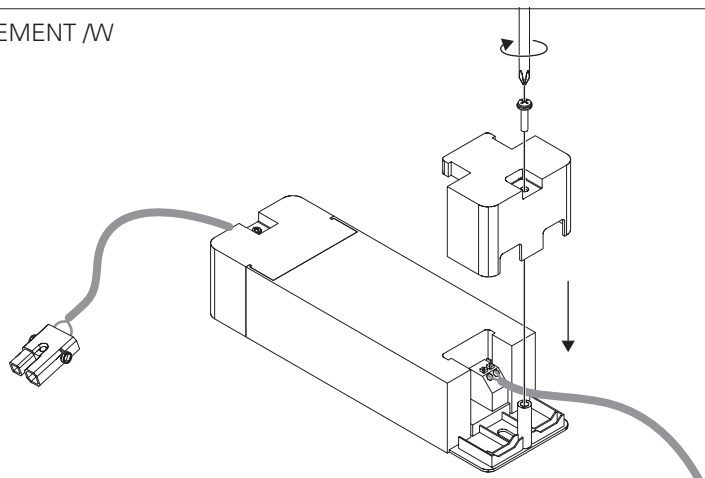

8 - 6th ELEMENT /W

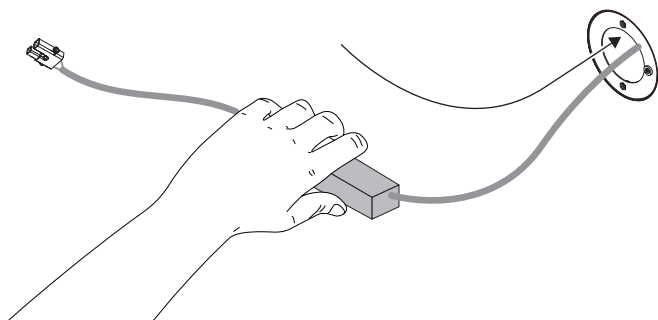

9 - 6th ELEMENT /W

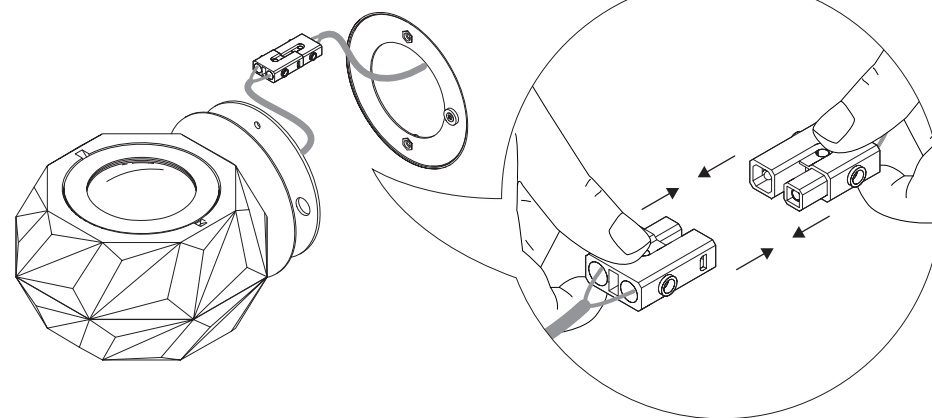

10 - 6th ELEMENT /W

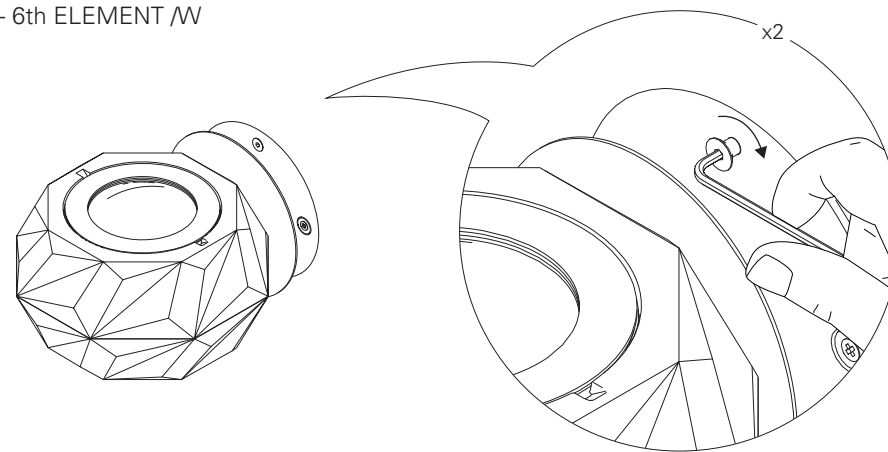

11 - 6th ELEMENT /W

