

11 - ELEEX

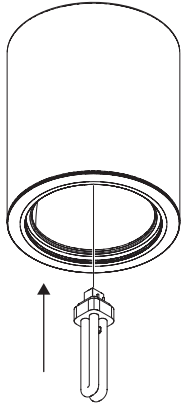

12 - ELEEX

GLASS/DIFFUSER OPTION
OPTION VERRE/DIFFUSEUR
OPTION GLASS/DIFFUSER
OPÇÃO VIDRO/DIFUSOR
OPCIÓN VIDRIO/ DIFUSOR

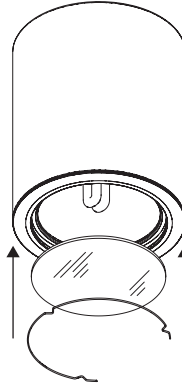

INDELAGUE™

HIGH TECH | LIGHTING SOLUTIONS



MADE IN
PORTUGAL

ELEEX

EN INSTALLATION INSTRUCTIONS
FR INSTRUCTIONS D'INSTALLATION
DE INSTALLATIONSANLEITUNG
PT INSTRUÇÕES DE MONTAGEM
ES INSTRUCCIONES DE MONTAJE

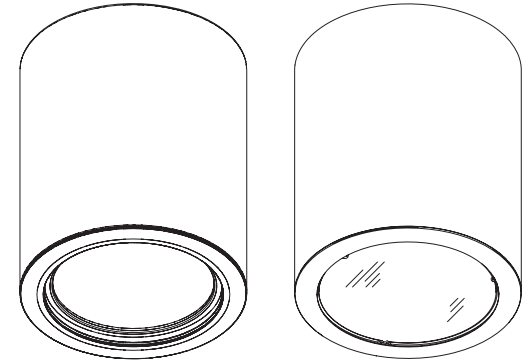

ELEEX



MAINTENANCE | ENTRETIEN | WARTUNG |
MANUTENÇÃO | MANTENIMIENTO

EN To replace lamps please reverse the steps 11-12 of this leaflet.
FR Pour remplacer les tubes inversez les étapes 11-12 de cette brochure.
DE Um die Lampen zu ersetzen müssen die Schritte 11-12 dieser Broschüre umgekehrt werden.
PT Para trocar lâmpadas deve inverter os passos 11-12 deste folheto.
ES Para cambiar las lámparas debe invertir los pasos 11-12 de este folleto.



EN If glass or diffuser break or crack, please replace it.
FR En cas de casse ou fissurement, remplacez le verre ou diffuseur.
DE Bei Bruch oder Riss, Glas oder Diffuser ersetzen.
PT Em caso de quebra ou fissura, substituir o vidro ou difusor.
ES En caso de rotura o fisura, sustituir el vidrio o difusor.

EN Read carefully the general terms and conditions of use and environmental concern with recycling attached. | **FR** Lire attentivement les conditions générales d'utilisations et de préoccupation environnementales avec les recyclage ci-joint. | **DE** Bitte lesen Sie die Allgemeinen Geschäftsbedingungen und Umweltbewusstsein über Recycling angeschlossen. | **PT** Ler atentamente as condições gerais de uso e preocupação ambiental com a reciclagem, em anexo. | **ES** Lea atentamente las condiciones generales de uso y preocupación ambiental con el reciclaje adjuntos.

EN We reserve the right to make changes on technical specifications, design and installation leaflet without prior notice. | **FR** Sous réserve de modifications au niveau de la conception, des spécifications techniques et de la notice. | **DE** Änderungen von Entwurf, technischen Daten und Bedienungsanleitungen bleiben vorbehalten. | **PT** O fabricante reserva-se no direito de realizar modificações no desenho, especificações técnicas e folheto, sem aviso prévio. | **ES** El fabricante se reserva el derecho de realizar modificaciones en el diseño, las especificaciones técnicas y el folleto.

ELEEX

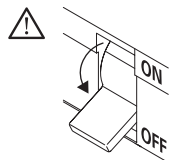

1 - ELEEX

GLASS/DIFFUSER OPTION
OPTION VERRE/DIFFUSEUR
OPTION GLASS/DIFFUSER
OPÇÃO VIDRO/DIFUSOR
OPCIÓN VIDRIO/ DIFUSOR

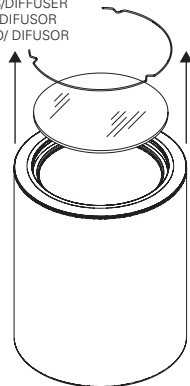

2 - ELEEX

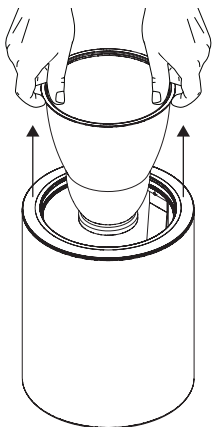

3 - ELEEX

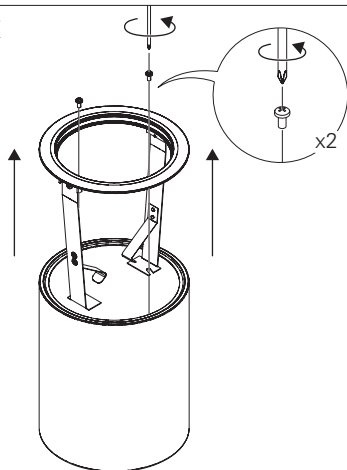

4 - ELEEX

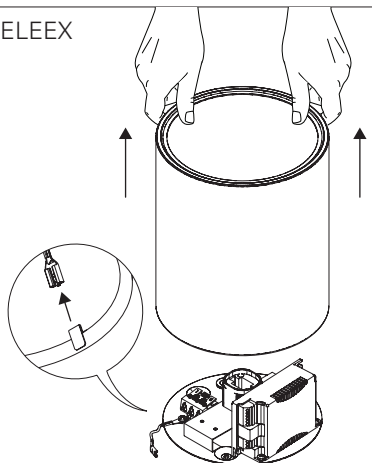

5 - ELEEX

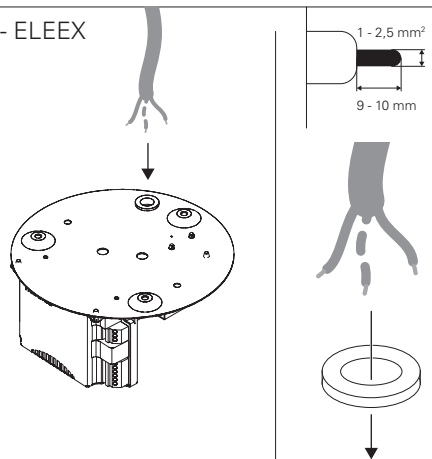

6 - ELEEX

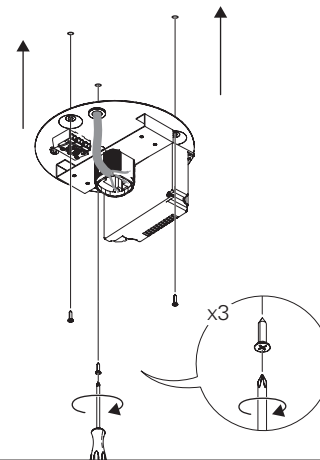

7 - ELEEX HF

STANDARD POWER SUPPLY
CÁBLAGE STANDARAD
STANDARD VERDRAHTUNG
ALIMENTAÇÃO ELÉCTRICA STANDARD
ELECTRIFICACIÓN ESTÁNDAR

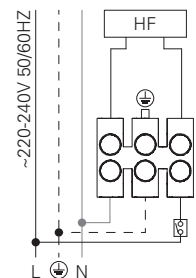

BLUE - N (NEUTRAL)
GREEN AND YELLOW - (EARTH)
BROWN - L (LIVE)

BLEU - N (NEUTRE)
VERT ET JAUNE - (TERRE)
MARRON - L (PHASE)

BLAU - N (NEUTRAL)
GRÜN UND GELB - (ERDE)
BRAUN - L (PHASE)

AZUL - N (NEUTRO)
VERDE E AMARELO - (TERRA)
CASTANHO - L (FASE)

AZUL - N (NEUTRAL)
VERDE Y AMARILLO - (TIERRA)
MARRÓN - L (FASE)

8 - ELEEX

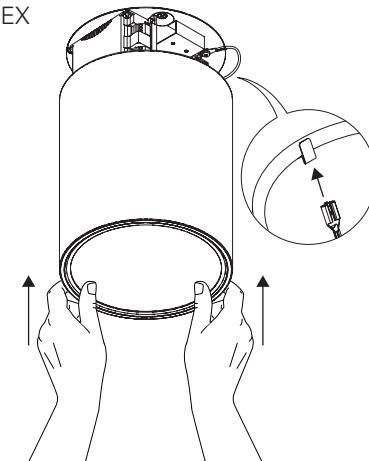

9 - ELEEX

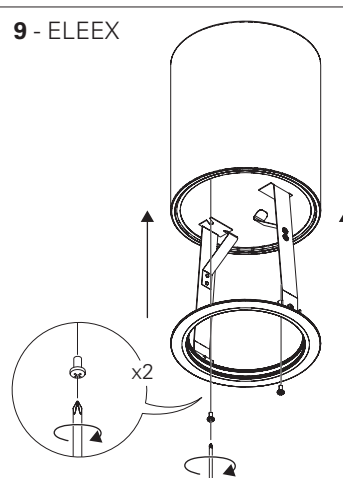

10 - ELEEX

